

Labfors 5

Version for Microorganisms

The Labfors 5 comes in two different versions which cover a wide range of microbial applications through to bioprocesses containing solids. Each version of Labfors 5 can be configured to your needs. The present data sheet contains all relevant data on the version for microorganisms.



Dimensions and Weights

Dimensions Single Unit

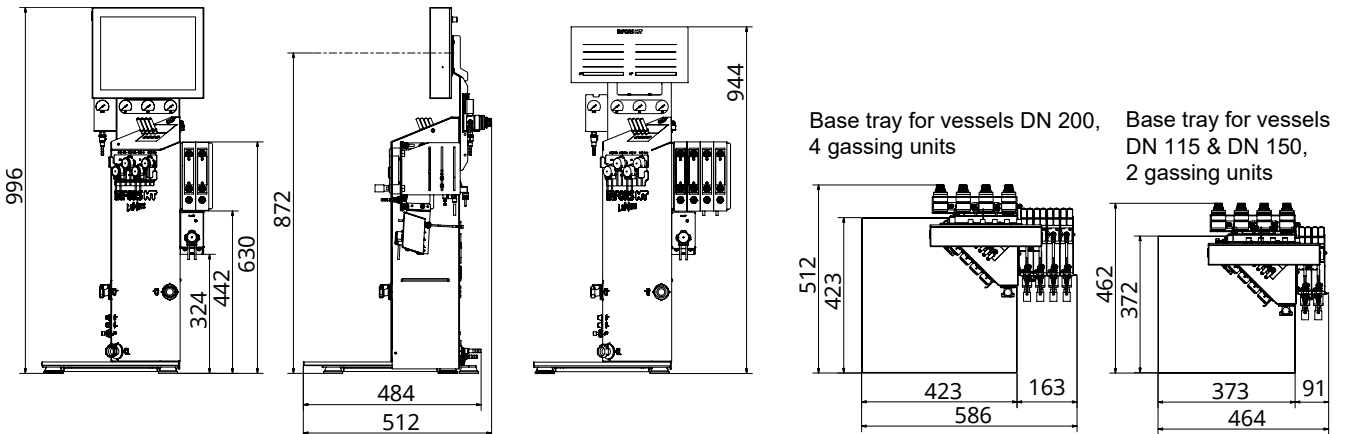

Dimensions Master Unit with 5 Satellite Units

6 units with standard base tray

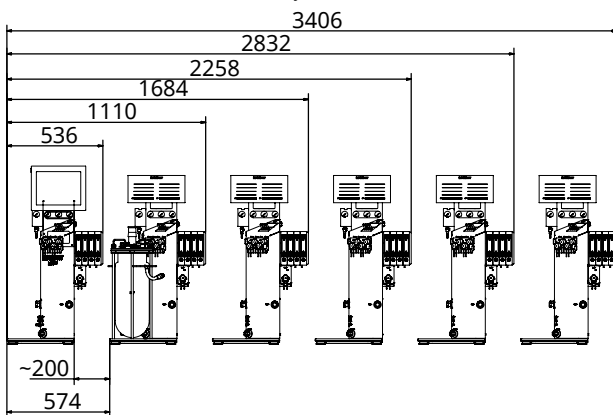

6 units with base tray for vessels DN 200

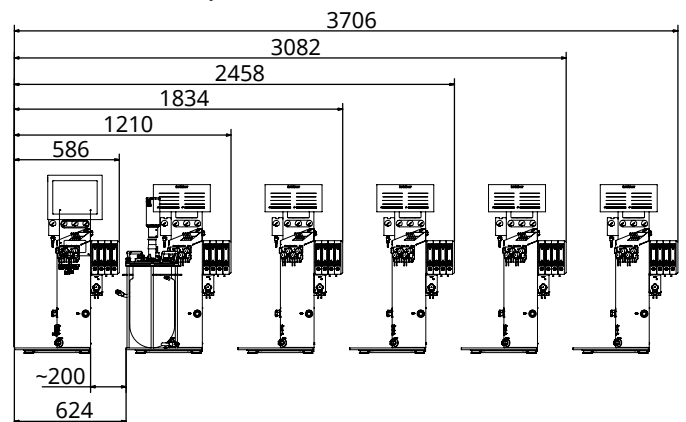

Dimensions of Culture Vessels

	2 L / DN 115	3.6 L / DN 115	7.5 L / DN 150	13 L / DN 200		2 L / DN 115	3.6 L / DN 115	7.5 L / DN 150	13 L / DN 200
D1	330 mm	330 mm	335 mm	365 mm	H1	373 mm	538 mm	635 mm	616 mm
D2	300 mm	300 mm	320 mm	365 mm	H2	453 mm	618 mm	717 mm	700 mm
D3	340 mm	340 mm	355 mm	420 mm	H3	514 mm	679 mm	776 mm	760 mm
D4	365 mm	365 mm	380 mm	435 mm					
D5	250 mm	250 mm	250 mm	290 mm					

Weight	
Touch screen operating panel	5 kg
Basic unit	25 kg

Culture Vessel

General	
Form	Cylindrical with round bottom
Model	Double walled
Material glass vessel	Borosilicate glass
Material top plate and built-in-parts	AISI 316L, electropolished
Material O-rings (in contact with product)	EPDM

Ports in top plate		Quantity acc. to vessel DN		
Diameter	Thread	DN 115	DN 150	DN 200
10 mm	None	2	2	2
12 mm	Pg13.5	6	6	5
19 mm	None	2	3	6

Vessel sizes				
Total volume, L	2.0	3.6	7.5	13.0
Max. working volume, L	1.2	2.3	5.0	10.0
Min. working volume, L	0.5	0.5	1.0	2.2
Nominal diameter (DN, inner diameter vessel), mm	115	115	150	200
Height, mm	205	370	465	445
Weight, kg ¹⁾	10	12	18	22

¹⁾ empty weight culture vessels in delivery state (equipped with default built-in-parts)

Stirrer

General		DC motor (standard)	High-torque motor (option)
Drive		Shaft with mechanical seal	
Direction of rotation of stirrer shaft		Counter-clockwise (top view)	
Bearing		Outside vessel, in drive hub	
Motor type		DC, brushless	Servomotor
Nominal power of motor		140 W	330 W
Nominal torque of motor		0.4 Nm	1.05 Nm
Min. rotation speed		80 min ⁻¹	20 min ⁻¹
Max. rotation speed with 2 impellers (standard)	Vessels DN 115	1500 min ⁻¹	1500 min ⁻¹
	Vessels DN 150	1200 min ⁻¹	1500 min ⁻¹
	Vessels DN 200	700 min ⁻¹	1250 min ⁻¹
Max. rotation speed with 3 impellers (option)	Vessels DN 115	1500 min ⁻¹	1500 min ⁻¹
	Vessels DN 150	1000 min ⁻¹	1500 min ⁻¹
	Vessels DN 200	600 min ⁻¹	1000 min ⁻¹
Accuracy measurement	at ≤ 1000 min ⁻¹	± 5 min ⁻¹	± 5 min ⁻¹
	at > 1000 min ⁻¹	1% setpoint	
Accuracy control	at ≤ 1000 min ⁻¹	≤ ± 5 min ⁻¹	≤ ± 5 min ⁻¹
	at > 1000 min ⁻¹	≤ 1% setpoint	

Impellers	
Type	Rushton impellers, 6 blades
Material	AISI 316L, electropolished
Quantity	2 (standard), 3 (option)

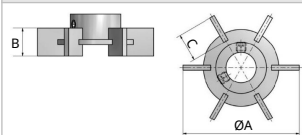
Dimensions impellers		DN 115	DN 150	DN 200
	A	46 mm	54 mm	70 mm
	B	11 mm	11 mm	13 mm
	C	11 mm	11 mm	19 mm

Temperature Control System

Heating		Water circulation in jacket, pump and heating 500 W integrated in basic unit
Cooling		With tap water via water circuit into vessel jacket Option: with chiller
Sensor		Pt100 1/3 DIN-B
Measurement range		0 °C to 145 °C
Control range		From 5 °C above inlet temperature to 70 °C
Accuracy measurement and control	at ≤ 60 °C	± 0.3 °C
	at > 60 °C	± 0.5 °C

Gassing System

General specifications	
Gas entry	Sparger
Specific gassing rate ¹⁾	2 min ⁻¹
Gas(es)	Air; Air + O ₂ ; Air + N ₂ ; Air + O ₂ + N ₂ ; CO ₂ ²⁾

¹⁾ Calculated for the max. working volume for all vessel sizes.

²⁾ CO₂ optional for pH control via sparger.

Gassing strategy variant Basic	
Gas flow control	One Rotameter
Accuracy rotameter	± 5 %
Gas mix control ³⁾	Solenoid valves, one per gas

Gassing strategy variants Standard and High End		
Gas flow control	Standard	One MFC
	High End	MFCs, one per gas
Accuracy measurement		± 1.5 % FS
Accuracy control		≤ ± 1.5 % FS
Gas mix control ³⁾	Standard	Solenoid valves, one per gas
	High End	via MFCs

³⁾ Only relevant for multi-gas configurations

Measurement ranges MFCs or rotameters in L min ⁻¹			
Vessel size	Basic (rotameter)	Standard and High End (MFC)	CO ₂ (sparger, MFC)
2 L	0.25 to 2.4	0.025 to 2.5	0.012 to 1.2
3.6 L	0.3 to 4.7	0.05 to 5	0.023 to 2.3
7.5 L	0.5 to 11	0.1 to 10	0.05 to 5
13 L	1 to 22	0.2 to 20	0.1 to 10

pH Control

General	
Control	Peristaltic pumps <i>Acid</i> and <i>Base</i> or with CO ₂ instead of acid
Control range	pH 2 to 12
Accuracy measurement	pH ± 0.1

Measurement system HAMILTON (digital)	
Sensor type	Easyferm Plus ARC
Measurement range	pH 0 to 14

Measurement system METTLER (digital)	
Sensor type	InPro 3253i, ISM
Measurement range	pH 0 to 12

Measurement system METTLER (analogue)	
Sensor type	405-DPAS-SC-K8S/120
Measurement range	pH 2 to 12

pO₂ Control

General	
Control via cascade	Stirrer, gas flow, gas mixture (addition of O ₂)
Control range	0 %-sat. to 100 %-sat.
Accuracy measurement	± 1 %

Measurement system HAMILTON (digital)	
Sensor type	Visiferm DO ARC / RS485-ECS
Measurement range	0 %-sat. to 300 %-sat.

Measurement system METTLER (digital)	
Sensor type	InPro6860i, ISM
Allowed temperature range	0 °C to 60 °C
Measurement range	0 %-sat. to 285 %-sat.

Measurement system METTLER (analogue)	
Sensor type	InPro 6820/25/080
Measurement range	0 %-sat. to 150 %-sat.

Antifoam Control

Sensor	Conductive with dosing needle
Control	Peristaltic pump <i>Antifoam</i>
Display	0 % (no foam) / 100 % (foam)

Pumps

Integrated pumps		
Type	Peristaltic	
Quantity	Digital	3 (Acid, Base, Antifoam)
	Analogue	Standard: 1 (Feed) Option: 2 additionally (Feed 2 and Feed 3)
Rotation speed	Digital	74 min ⁻¹ / fixed rotation speed
	Analogue	0 min ⁻¹ to 74 min ⁻¹ / adjustable within range of 0 % to 100 % (increment 0.1 %)
Accuracy	± 1 % FS	

External pump(s) (option)	
Type	Watson Marlow 120U/DV, peristaltic
Rotation speed	Adjustable within range of 0 % to 100 %

Hoses	Standard	Option 1	Option 2
Inside diameter	1.0 mm	0.5 mm	2.5 mm
Wall thickness	1.1 mm	1.15 mm	1.0 mm
Delivery rate min., mL min ⁻¹	0.0034	0.0012	0.017
Delivery rate max., mL min ⁻¹	3.52	1.12	16.13
Material	PharMed BPT		

Operating Panel

HMI	12" colour touch screen
Protection	IP 66

Turbidity Measurement (Optional)

Variant OPTEK	
Sensor type	ASD12-N
Optical path lengths	OPL01 (highest cell densities) OPL05 (higher cell densities) OPL10 (lower cell densities)
Measurement range absorption	0 CU to 4 CU

Variant aquila biolabs	
Sensor type	CGQ BioR
Measurement modes	Green (521 nm) (low cell densities), Infrared (940 nm) (high cell densities)
Measurement range	0 to 1000

Permissive Measurement (Optional)

Sensor type	ABER Futura
Measurement range permittivity	0 pF cm ⁻¹ to 400 pF cm ⁻¹
Measurement range conductivity	0 mS cm ⁻¹ to 40 mS cm ⁻¹

Exit Gas Analysis (Optional)

		CO ₂	O ₂
Ranges, Vol. %	BlueInOne Ferm	0 to 10	1 to 50
		0 to 25	1 to 50
	BlueInOne Cell	0 to 10	0 to 100
	BlueVary (cartridge ZrO ₂)	0 to 10	0.1 to 50
		0 to 25	0.1 to 50
	BlueVary (cartridge eC)	0 to 10	0 to 100
0 to 25		0 to 100	
0 to 25		0 to 25	

Sensor accuracy	BlueInOne Ferm, BlueInOne Cell	< ± 0.2 % FS, ± 3 % of value
	BlueVary CO ₂	± 3 % of value, ± 0.2 % of range; ± 5 % of value, ± 0.5 % of range for 50 % range
	BlueVary O ₂ (eC and ZrO ₂)	± 3 % of value, ± 0.2 % of range
Sensor drift	BlueInOne Ferm, BlueInOne Cell	< ± 2 % value / year
	BlueVary	0.2 % value / month

Redox Measurement (Optional)

Measurement system HAMILTON digital	
Sensor type	Easyferm Plus ORP ARC
Measurement range	-1500 mV to +1500 mV

Measurement system METTLER analogue	
Sensor type	Pt4805-DPAS-SC-K8S
Measurement range	-2000 mV to +2000 mV

Conductivity Measurement (Optional)

Sensor type	Conducell 4USF ARC with built-in electronics
Measurement range	1 µS cm ⁻¹ to 300000 µS cm ⁻¹
Accuracy	± 3 % at 1 µS cm ⁻¹ to 100000 µS cm ⁻¹ ± 5 % at 100 µS cm ⁻¹ to 300000 µS cm ⁻¹

Pressure Control (Optional)

Sensor	Piezo-resistive pressure sensor
Control	Solenoid valve
Control range	0 mbar to 400 mbar

Balances (Option)

A: Mettler MS6002TSDR/00 C: Kern FKB 6K0.02
B: Mettler MS32001L/01 D: Kern DS 30K0.1

	A	B	C	D
Max. capacity, kg	6.2	32.2	6	30
Readability, g	0.1	0.1	0.02	0.1
Power supply	100 to 240 V, 50/60 Hz, 0.3 A			

Note: In order to use one of the supported balances, the balance must be prepared and configured by INFORS HT.

Operating Conditions

Ambient temperature	5 °C to 40 °C
Ambient humidity	20 % to 90 %
Altitude operating location	max. 2000 m.a.s.l
Pollution degree as per EN 61010-1	2
Minimum distance	150 mm

Interfaces

25 pin Dsub Multi I/O	analog	4 x IN (0/4 mA to 20 mA) 6 x OUT (0/4 mA to 20 mA)
	digital	2 x OUT
9-pin D-SUB, RS232		Balance input
USB 2.0		Backups/service purposes
Ethernet, RJ45		To integrate the device into a network

Various

Sound pressure	< 70 dB (A)
----------------	-------------

Electrical Connection and Power Values

	Type 230 V	Type 115 V
Mains voltage	230 VAC	115 VAC
Mains frequency	50 / 60 Hz	60 Hz
Max. current consumption	4 A	8 A
Fuse (two 5 x 20 mm fuses, time lag)	4 A	8 A

Connections/Utilities

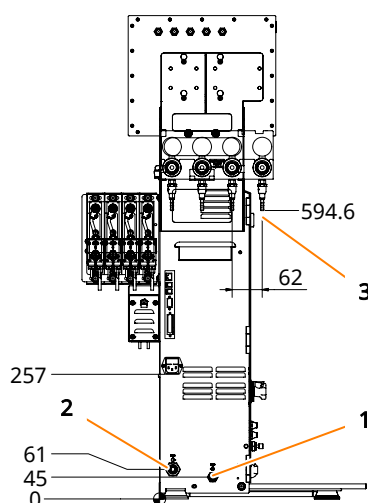

Pos.	Connection	Size	Pressure	Requirements
1	Water inlet	Hose nozzle 8.3 mm	2 bar ± 1 bar	<ul style="list-style-type: none"> Inlet temperature: 10 °C to 20 °C Max. flow cooling vessel and exit gas cooler: 1.6 L min⁻¹ Water quality: CaCO₃ concentration 0 mmol L⁻¹ to 1.5 mmol L⁻¹ The heating system has a protection against dry running, which is based on measurement of conductivity. The heating will not work when using demineralised or distilled water as cooling agent.
2	Water outlet	Hose nozzle 10 mm	No back pressure	<ul style="list-style-type: none"> Designed to withstand water temperatures of up to 80 °C
3	Gas inlets	Hose nozzle 7 mm	2 bar ± 0.5 bar	<ul style="list-style-type: none"> Dry, clean and free of oil and dust Compressed air: Class 1,2,3,4 as per DIN ISO 8573-1
	Exit Gas	Hose nozzle 8 mm	No back pressure	

eve[®]



eve[®] is a platform software for planning, execution and analysis of bioprocesses. eve[®] allows you to record bioprocess data and store it in a central database. The software offers workflows from simple bioprocesses to the planning and execution of complex strategies with various phases.

eve[®] makes it possible to generate and store bioprocess knowledge. Various libraries for storing information on organisms and culture media are available. Thanks to soft-sensors, additional knowledge can be generated.

In addition to INFORS HT products, biotech machines and analysis devices from third-part manufacturers can be connected. This makes it possible to holistically control, monitor and analyse bioprocesses using a single software.

eve[®] is installed on a centralised server. Access takes place via a browser, no client side installation is required. Bioprocess data is therefore available directly via the browser and independent of the operating system.

Various packages of the software are available. This makes it possible to adapt it to the individual needs and requirements of its users. eve[®] (in the premium version) is also suitable for working in a validated environment as per FDA CFR 21 Part 11.